

MATERIAL SPECIFICATION

PE VENTILATION PIPE



PRODUCT DESCRIPTION	400 MM VENTILATION PIPE 40 x 3,7 MM AND 32 x 2,9 MM BLACK
TYPE	FRICTION WELDED PRODUCT
CUSTOMER / PRODUCT	STANDARD ARTICLE / ART NO. 4.835.040 AND 4.835.032

GENERAL

A PE PIPE, 40 / 32 MM X 3, 7 / 2,9 MM x 400 MM WITH FILTER ON ONE END.

MECHANICAL AND PHYSICAL REQUIREMENTS / TEST PROCEDURE

PE DUCT PIPE IS PRODUCED ACCORDANCE WITH STANDARDS EN 12201

FOR DIMENSIONS AND TEST, PROCEED IN ACCORDANCE TO ISO 9001

FILTER IS INJECTION MOULDED AND MADE OF PE

INSTALLATION CONDITIONS

INSTALLATION CONDITIONS CAN BE DONE IN THE TEMPERATURE CONDITIONS $-25^{\circ}\text{C} < t < 40^{\circ}\text{C}$

PROPERTIES OF PRODUCT

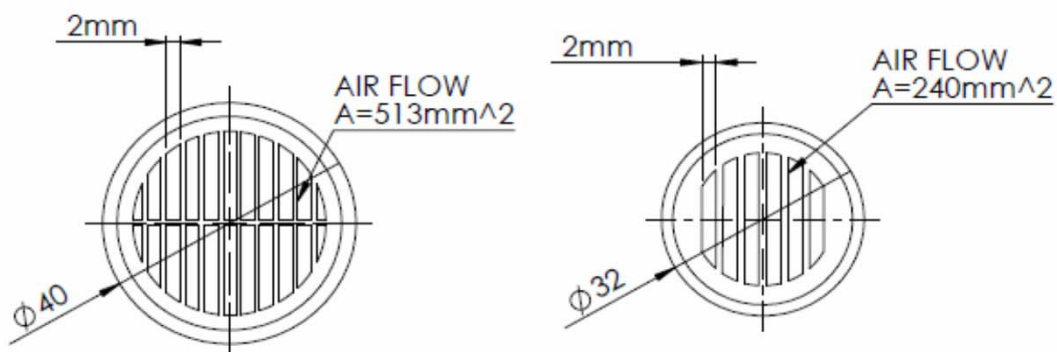

PACKING SPECIFICATIONS

ART NO.	PIECES IN BOX	BOX SIZE [cm]	WEIGHT [kg]
4.835.032	180	30 x 60 x 42	15 Kg
4.835.040	112	30 x 60 x 42	17 kg